

**MISSOURI**  
DEPARTMENT OF  
NATURAL RESOURCES  
MISSOURI AIR CONSERVATION COMMISSION  
AIR POLLUTION CONTROL PROGRAM

# PERMIT TO CONSTRUCT

PERMIT BY RULE

Under the authority of RSMo 643 and the Federal Clean Air Act the applicant is authorized to construct and operate the air contaminant source(s) described below, in accordance with the laws, rules, and conditions set forth here in.

**Construction Permit Number:** 042017-008  
**Project Number:** 2017-04-014  
**Installation ID:** 017-0024

**Installation Name and Address**

Bollinger County Crematory  
MO Hwy 51 South  
Marble Hill, MO 63764  
Bollinger County

**Parent Company's Name and Address**

Bollinger County Memorial, Incorporated  
410 Union Street  
Marble Hill, MO 63764

**Project Description:**

A Matthews Environmental Solutions Power Pak I (IE43-PPI) human cremation unit.

APR 19 2017

Effective Date

Director of Designee  
Department of Natural Resources

STANDARD CONDITIONS:

Permission to construct may be revoked if you fail to begin construction or modification within two years from the effective date of this permit. Permittee should notify the Enforcement and Compliance Section of the Air Pollution Control Program if construction or modification is not started within two years after the effective date of this permit, or if construction or modification is suspended for one year or more.

You will be in violation of 10 CSR 10-6.060 if you fail to adhere to the specifications and conditions listed in your permit-by-rule application and this permit. Specifically, all air contaminant control devices shall be operated and maintained as specified in the application, associated plans and specifications.

You must notify the Department's regional office responsible for the area within which you are located within 15 days after the actual start-up of this (these) air contaminant source(s).

A copy of the permit application and this permit and permit review shall be kept at the installation address and shall be made available to Department's personnel upon request.

You may appeal this permit or any of the listed special conditions to the Administrative Hearing Commission (AHC), P.O. Box 1557, Jefferson City, MO 65102, as provided in RSMo 643.075.6 and 621.250.3. If you choose to appeal, you must file a petition with the AHC within 30 days after the date this decision was mailed or the date it was delivered, whichever date was earlier. If any such petition is sent by registered mail or certified mail, it will be deemed filed on the date it is mailed. If it is sent by any method other than registered mail or certified mail, it will be deemed filed on the date it is received by the AHC.

If you choose not to appeal, this certificate, the project review and your application and associated correspondence constitutes your permit to construct. The permit allows you to construct and operate your air contaminant sources(s), but in no way relieves you of your obligation to comply with all applicable provisions of the Missouri Air Conservation Law, regulations of the Missouri Department of Natural Resources and other applicable federal, state and local laws and ordinances.

The Air Pollution Control Program invites your questions regarding this air pollution permit. Please contact the Construction Permit Unit using the contact information below.

Contact Information:  
Missouri Department of Natural Resources  
Air Pollution Control Program  
P.O. Box 176  
Jefferson City, MO 65102-0176  
(573) 751-4817

The regional office information can be found at the following website:

<http://dnr.mo.gov/regions/>

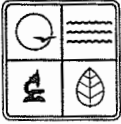

MISSOURI DEPARTMENT OF NATURAL RESOURCES  
 AIR POLLUTION CONTROL PROGRAM  
 P.O. BOX 176, JEFFERSON CITY, MO 65102-0176  
**APPLICATION FOR AUTHORITY TO CONSTRUCT  
 PERMIT BY RULE NOTIFICATION  
 CREMATORIES AND ANIMAL INCINERATORS**

**APCP USE ONLY**

CHECK NO.	CHECK RECEIVED (MM/DD/YY)
CHECK AMOUNT \$	CHECK DATE (MM/DD/YY)
PROJECT NO.	PERMIT NO.

**SECTION A: GENERAL NOTIFICATION INFORMATION - ALL NOTIFICATIONS MUST BE ACCOMPANIED BY A \$700 FEE.**

**SECTION A-1: GENERAL INSTALLATION INFORMATION**

1. INSTALLATION NAME <b>BOLLINGER COUNTY CREMATORY</b>		2. FIPS <b>017</b>	3. PLANT NO.
4. INSTALLATION STREET ADDRESS <b>MO HWY 51 South</b>			
5. INSTALLATION MAILING ADDRESS <b>410 Union Street,</b>			
6. CITY <b>Marble Hill,</b>		STATE <b>MO</b>	ZIP CODE <b>63764</b>
7. COUNTY NAME <b>Bollinger</b>	8. <b>1/4, of PT N1/2, LT. 1SW</b> SECTION 18 TOWNSHIP30 RANGE10		
9. PARENT COMPANY <b>BOLLINGER COUNTY MEMORIAL, INCORPORATED</b>			
10. PARENT COMPANY MAILING ADDRESS <b>410 Union Street,</b>			
11. CITY <b>Marble Hill,</b>		STATE <b>MO</b>	ZIP CODE <b>63764</b>
12. INSTALLATION CONTACT PERSON <b>Michael Liley</b>		13. CONTACT PERSON'S TITLE <b>Secretary</b>	
14. CONTACT PERSON'S MAILING ADDRESS <b>410 Union Street, Marble Hill, Mo 63764</b>			
15. INSTALLATION CONTACT TELEPHONE NO. <b>( 573 ) 238-2820</b>		16. INSTALLATION CONTACT FAX NO. <b>(573 ) 238-3859</b>	
17. INSTALLATION CONTACT E-MAIL ADDRESS <b>michael@lileyfuneralhomes.com</b>			
18. PROJECTED DATE TO COMMENCE CONSTRUCTION <b>April 15, 2017</b>		19. PROJECT DATE OF OPERATION STARTUP <b>August 1, 2017</b>	

**SECTION A-2: INSTALLATION DESCRIPTION**

20.  
 Installation of a Matthews Environmental Solutions Power Pak I (IE43-PPI) human cremation unit.

RECEIVED  
 2017 APR - 6 AM 11:31  
 AIR POLLUTION  
 CONTROL PERMIT

**SECTION A-3: CERTIFICATION STATEMENT**

I certify that I have personally examined and am familiar with the information in this application and believe that the information submitted is accurate and complete. I am aware that making a false statement or misrepresentation in this application is grounds for denying or revoking this permit.

21. SIGNATURE OF RESPONSIBLE OFFICIAL <i>Michael L. Liley</i>		22. DATE <b>March 24, 2017</b>
23. TYPE OR PRINT NAME OF RESPONSIBLE OFFICIAL <b>Michael L. Liley</b>		24. RESPONSIBLE OFFICIAL'S TELEPHONE NUMBER <b>( 573 ) 238-2820</b>
25. TITLE OF RESPONSIBLE OFFICIAL <b>Corporate Secretary</b>		

**SECTION B: SPECIAL CONDITIONS FOR CREMATORIES AND ANIMAL INCINERATORS**

Construction and operation of this new air pollution source is subject to the special conditions listed below. These special conditions are based on the authority granted to the Missouri Air Pollution Control Program by the Missouri Air Conservation Law (specifically RSMo. 643.075) and by the Missouri Rules listed in Title 10, Division 10 of the Code of State Regulations (specifically 10 CSR 10-6.062 "Construction Permits by Rule").

Please indicate by marking the appropriate box as to whether or not the emission source complies with the rule listed in the applicable emission limit or standard. If any of the applicable emission source boxes are checked no, your source is not eligible for a crematories and animal incinerators permit by rule.

This Permit By Rule applies only to Crematories and Animal Incinerators constructed after October 31, 2003.

SPECIAL CONDITION	EMISSION SOURCE COMPLY?	APPLICABLE EMISSION LIMIT OR STANDARD	METHOD OF COMPLIANCE
10 CSR 10-6.062(3)(B)2.A.	<input checked="" type="checkbox"/> YES <input type="checkbox"/> NO	The materials to be disposed of shall be limited to noninfectious human materials removed during surgery, labor and delivery, autopsy, or biopsy including body parts, tissues and fetuses, organs, bulk blood and body fluids, blood or tissue laboratory specimens, and other noninfectious anatomical remains or animal carcasses in whole or in part. The owner or operator shall minimize the amount of packaging fed to the incinerator, particularly plastic containing chlorine. The incinerators shall not be used to dispose of other non-biological medical wastes including, but not limited to, sharps, rubber gloves, intravenous bags, tubing, and metal parts.	Proper work practice.
10 CSR 10-6.062(3)(B)2.B.	<input checked="" type="checkbox"/> YES <input type="checkbox"/> NO	The manufacturer's rated capacity (burn rate) shall be two hundred (200) pounds per hour or less.	Proper work practice.
10 CSR 10-6.062(3)(B)2.C.	<input checked="" type="checkbox"/> YES <input type="checkbox"/> NO	The incinerator shall be a dual-chamber design.	Proper work practice.
10 CSR 10-6.062(3)(B)2.D.	<input checked="" type="checkbox"/> YES <input type="checkbox"/> NO	Burners shall be located in each chamber, sized to manufacturer's specifications, and operated as necessary to maintain the minimum temperature requirements of subparagraph 10 CSR 10-6.062(3)(B)2.E. at all times when the unit is burning waste.	Proper work practice.
10 CSR 10-6.062(3)(B)2.E.	<input checked="" type="checkbox"/> YES <input type="checkbox"/> NO	Excluding crematories, the second chamber must be designed to maintain a temperature of one thousand six hundred degrees Fahrenheit (1,600°F) or more with a gas residence time of one-half (1/2) second or more. The temperature shall be monitored with equipment that is accurate to plus or minus two percent (±2%) and continuously recorded. The thermocouples or radiation pyrometers shall be fitted to the incinerator and wired into a manual reset noise alarm such that if the temperature of either of the two (2) chambers falls below the minimum temperature above, the alarm will sound at which time plant personnel shall take immediate measures to either correct the problem or cease operation of the incinerator until the problem is corrected	Proper work practice and maintenance of proper alarm records. These records shall be maintained for not less than five (5) years, and they shall be immediately available to any Missouri Department of Natural Resources personnel upon request.
10 CSR 10-6.062(3)(B)2.F.	<input checked="" type="checkbox"/> YES <input type="checkbox"/> NO	There shall be no obstruction to stack flow, such as by rain caps, unless such devices are designed to automatically open when the incinerator is operated. Properly installed and maintained spark arresters are not considered obstructions.	Proper work practice.

**SECTION B: SPECIAL CONDITIONS FOR CREMATORIES AND ANIMAL INCINERATORS (CONTINUED)**

SPECIAL CONDITION	EMISSION SOURCE COMPLY?	APPLICABLE EMISSION LIMIT OR STANDARD	METHOD OF COMPLIANCE
10 CSR 10-6.062(3)(B)2.G.	<input checked="" type="checkbox"/> YES <input type="checkbox"/> NO	Each incinerator operator shall be trained in the incinerator operating procedures as developed by the American Society of Mechanical Engineers (ASME), by the incinerator manufacturer, or by a trained individual with more than one (1) year experience in the operation of the incinerator that the trainee will be operating. Minimum training shall include basic combustion control parameters of the incinerator and all emergency procedures to be followed should the incinerator malfunction or exceed operating parameters. An operator who meets the training requirements of this condition shall be on duty and immediately accessible during all periods of operation. The manufacturer's operating instructions and guidelines shall be posted at the unit and the unit shall be operated in accordance with these instructions.	Proper work practice and maintenance of proper operator training records. These records shall be maintained for not less than five (5) years, and they shall be immediately available to any Missouri Department of Natural Resources personnel upon request.
10 CSR 10-6.062(3)(B)2.H.	<input checked="" type="checkbox"/> YES <input type="checkbox"/> NO	The incinerator shall have an opacity of less than ten percent (10%) at all times.	Proper work practice such that no opacity violations are noted.
10 CSR 10-6.062(3)(B)2.I.	<input checked="" type="checkbox"/> YES <input type="checkbox"/> NO	Heat shall be provided by the combustion of natural gas, liquid petroleum gas, or Number 2 fuel oil with less than three-tenths percent (0.3%) sulfur by weight, or by electric power.	Proper work practice.
10 CSR 10-6.062(3)(B)2.J.	<input checked="" type="checkbox"/> YES <input type="checkbox"/> NO	The operator shall maintain a log of all alarm trips and the resulting action taken. A written certification of the appropriate training received by the operator, with the date of training, that includes a list of the instructor's qualifications or ASME certification school shall be maintained for each operator. The operator shall maintain an accurate record of the monthly amount and type of waste combusted.	Determined through proper alarm and operator training record keeping. These records shall be maintained for not less than five (5) years, and they shall be immediately available to any Missouri Department of Natural Resources personnel upon request.

**SECTION C: OTHER POTENTIALLY APPLICABLE REQUIREMENTS**

This section is intended to identify regulations that may apply to this installation. There may be others not listed that apply. To determine rule applicability and specific standards please consult the appropriate sections in the Code of Federal Regulations (CFR) and Code of State Regulations (CSR) for the full text of the applicable requirements. A copy of the CSR can be found at <http://www.sos.mo.gov/adrules/csr/current/10csr/10csr>

Please note: this permit allows you to construct and operate your air contaminant source(s), but in no way relieves you of your obligation to comply with all applicable provisions of the Missouri Air Conservation Law, regulations of the Missouri Department of Natural Resources, and other applicable federal, state, and local laws and ordinances.

REGULATION OR CONSTRUCTION PERMIT REFERENCE	APPLICABLE EMISSION LIMIT OR STANDARD	METHOD OF COMPLIANCE
10 CSR 10-6.045 Open Burning Restrictions	Shall not conduct, cause, permit or allow the disposal of tires, petroleum-based products, trade waste, construction or demolition waste, salvage operation waste or asbestos containing materials by open burning, except as allowed in the rule.	Any person intending to engage in open burning shall submit a request to the Director.
10 CSR 10-6.050, Start-up, Shutdown and Malfunction Conditions	Shall not commence construction or modification of any installation subject to this rule; begin operation after construction or modification; or begin operation of any installation which has been shut down longer than 5 years without first obtaining a permit.	In the event of a malfunction, which results in excess emissions that exceed 1 hr, the permittee shall implement corrective action and submit reports.
10 CSR 10-6.065, Operating Permits	The permittee shall comply with all applicable requirements identified in the operating permit (OP) and retain a copy of the OP on-site and make available to any Missouri Department of Natural Resources personnel upon request.	As required by the rule, the permittee shall submit an operating permit application and submit an annual compliance certification in accordance with the regulation. The permittee shall maintain a current equipment list on-site with the date of installation of the equipment.
10 CSR 10-6.070 New Source Performance Regulations	The following federal NSPS standards may apply: (Ec) Medical Waste Incinerators. Standards of Performance for Incinerators.	As required by regulations.
10 CSR 10-6.110, Submission of Emission Data, Emission Fees and Process Information	Submittal of Emission Inventory Questionnaire (EIQ) and emission fees by frequency noted in 10 CSR 10-6.110.	The permittee shall complete and submit an EIQ and emission fees in accordance with 10 CSR 10-6.110.
10 CSR 10-6.165, Restriction of Emission of Odors	No person may cause, permit or allow the emission of odorous matter in concentrations and frequencies or for durations that odor can be perceived when one (1) volume of odorous air is diluted to seven (7) volumes of odor-free air for two (2) separate trails not less than 15 minutes apart within the period of 1 hour. The odor evaluation shall be taken at a location outside of the installation's property boundary	No odor violations noted, if and when scentometer readings taken.
10 CSR 10-6.200 Hospital, Medical, Infectious Waste Incinerators	No owner or operator shall cause to be discharged into the atmosphere any gases that contain stack emissions in excess of those listed in 10 CSR 10-6.200(3)(A).	Proper work practice and maintenance of appropriate performance test results.
10 CSR 10-5.170 Control of Odors From Processing Animal Matter.	Applies to installations in St. Louis, St. Charles, Jefferson and Franklin counties and the City of St. Louis.  No person shall operate or use any device, machine, equipment, or other contrivance for the reduction of animal matter unless all gases, vapors, and gas-entrained effluents from the facility are incinerated at a temperature of not less than 1,200 °F for a period of not less than 0.3 seconds and otherwise in compliance with this rule.	Proper work practice.

# PLOT PLAN

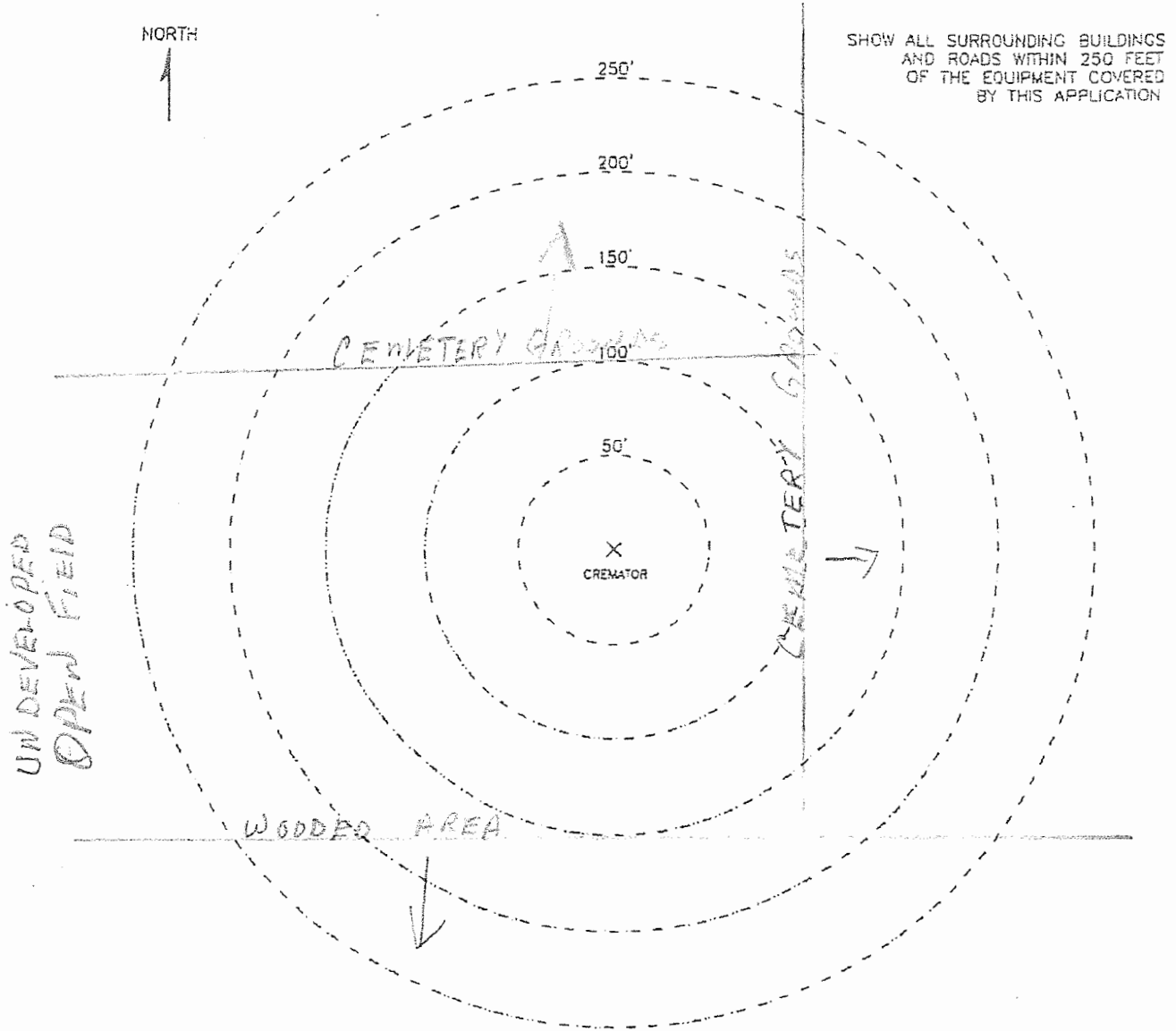

INSTRUCTIONS

1. INDICATE LOCATION AND TYPE OF BUILDING BY THE USE OF SMALL NUMBERED CIRCLES WITH THE DESCRIPTION BELOW.
2. SHOW ROADS AS LINES REPRESENTING THE ROAD EDGES. INDICATE STREET NAMES AND HIGHWAY NUMBERS.
3. SHOW WOODED OR CLEARED AREA BY APPROXIMATE BOUNDARY LINES AND THE WORDS "WOODS," "CLEARED," "CORNFIELD," ETC.

STRUCTURE    DESCRIPTION

- (1)
- (2)
- (3)
- (4)
- (5)
- (6)
- (7)
- (8)
- (9)
- (10)

M10 Highway 51 South

# PROCESS FLOW DIAGRAM CREMATOR

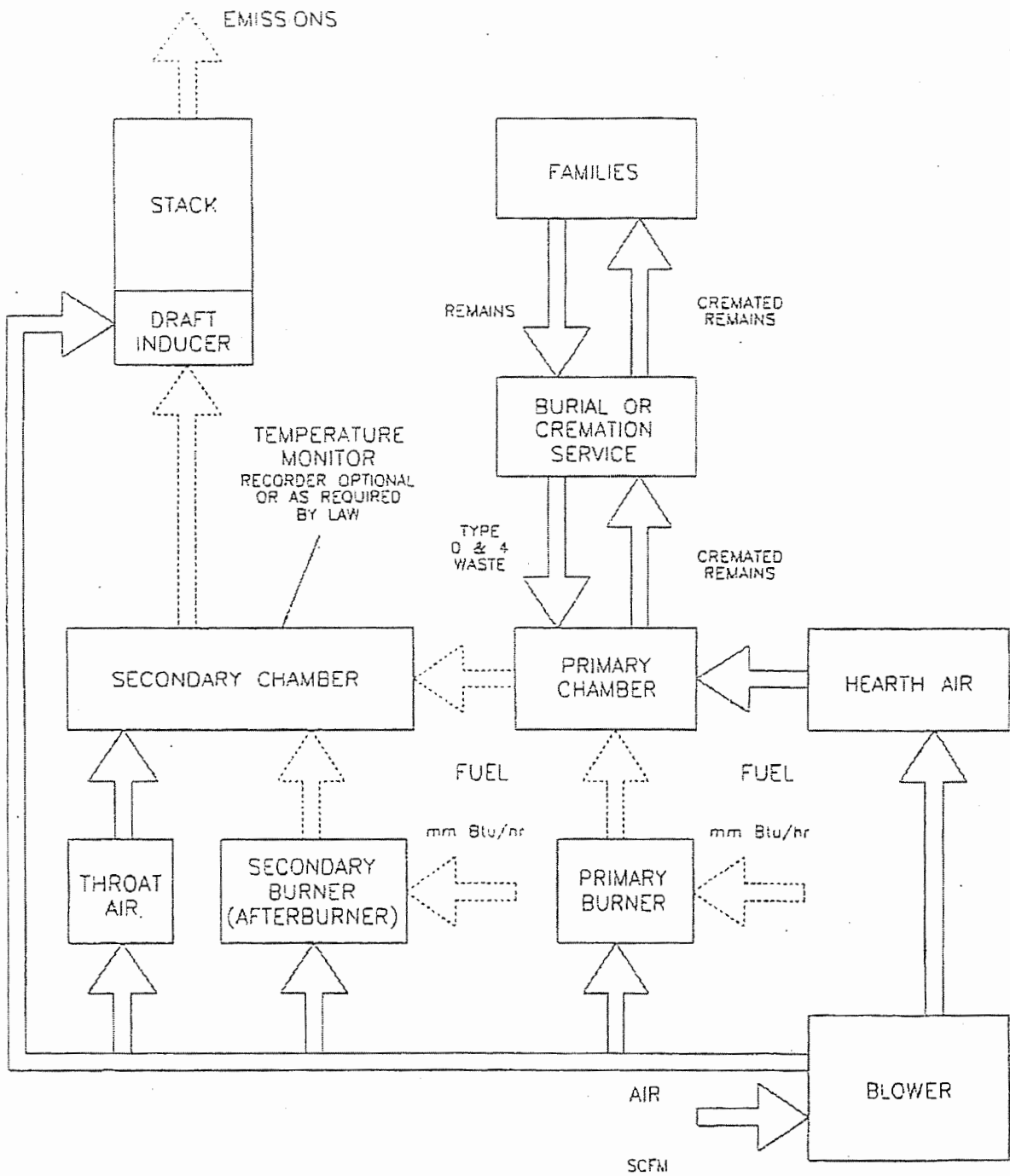



SPECIFICATIONS- Model Power-Pak I

1. Equipment Type..... Model Power-Pak I
  - A. Model No. .... IE43-PP1
  - B. Underwriters Laboratories Listing and File No. ... 87E8; MH14647
2. Dimensions
  - A. Footprint ..... 12' - 6 ½" x 5' - 3" (3.82 m x 1.60 m)
  - B. Maximum Length..... 14' - 8" (4.47 m)
  - C. Maximum Width ..... 6' - 5" (1.96 m)
  - D. Maximum Height..... 8' - 4" (2.54 m)
  - E. Chamber Loading Opening ..... 25 ¾" H x 39 ½" W (654 mm x 1003 mm)
3. Weight ..... 23,400 lbs. (10,614 kg)
4. Utility/Air Requirements
  - A. Gross Gas Input, Natural or LP Gas..... 2,700,000 BTU/hr. (2,848,651 kJ/h)  
3,000,000 BTU/hr. (3,165,168 kJ/h) if operating  
temperature is greater than 1,600° F (871° C)
    - Running Gas Pressure, Natural Gas ..... 11 inches (279.4 mm) water column or greater
    - Running Gas Pressure, LP Gas ..... 11 inches (279.4 mm) water column or greater
  - B. Electrical Supply..... 230 volt, 3Ø or 1Ø, 50/60 hz (other available)
  - C. Air Supply..... 2,500 cfm (70.8 standard m<sup>3</sup>/min)
5. Incineration Capacity ..... 150 lbs./hr. (68 kg/h)
6. Typical Loading Capacity of Waste Types..... 750 lbs. (340.2 kg)
7. Construction and Safety Standards..... Incineration Institute of America, Underwriters  
Laboratories, Canadian Standards Association
8. Steel Structure Construction
  - A. Frame ..... 2" (51 mm) square tubing
  - B. Front/Rear Plates ..... 3/8" (9.5 mm) plate
  - C. Floor Plates..... 3/16" (5 mm) plate
  - D. Outer Side Casing..... 12 gauge (3 mm) plate
  - E. Inner Side Casing..... 12 gauge (3 mm) plate
9. Stack Construction
  - A. Inner Wall..... 3" (76 mm) castable
  - B. Outer Wall..... 12 gauge (3 mm) stainless steel sheet with  
welded seams. (unlined stack available)
10. Draft Nozzle Construction..... Schedule 40 type 316 s.s. pipe, welded  
connections
11. Main Chamber Door Construction
  - A. Steel Shell..... 3/16" (5 mm) steel, welded with reinforcement
  - B. Outer Refractory..... 1" (25 mm) insulating block
  - C. Inner Refractory ..... 4½" (110 mm) insulating firebrick

## SPECIFICATIONS- Model Power-Pak I

12. Primary Chamber Wall Construction
- |                                     |                              |
|-------------------------------------|------------------------------|
| A. Outer Casing Wall.....           | 12 gauge (3 mm) sheet        |
| B. Inner Frame/Air Compartment..... | 2" (51 mm) air compartment   |
| C. Inner Casing Wall.....           | 12 gauge (3 mm) sheet        |
| D. Outer Refractory Wall.....       | 5" (127 mm) insulating block |
| E. Inner Refractory Wall .....      | 4½" (114 mm) firebrick       |
13. Secondary Chamber Wall Construction
- |                                     |                              |
|-------------------------------------|------------------------------|
| A. Outer Casing Wall.....           | 12 gauge (3 mm) sheet        |
| B. Inner Frame/Air Compartment..... | 2" (51 mm) air compartment   |
| C. Inner Casing Wall.....           | 12 gauge (3 mm) sheet        |
| D. Outer Refractory Wall.....       | 6" (152 mm) insulating block |
| E. Inner Refractory Wall .....      | 4½" (114 mm) firebrick       |
14. Refractory Temperature Ratings
- |                                      |                     |
|--------------------------------------|---------------------|
| A. Standard Firebrick.....           | 3,100° F. (1704° C) |
| B. Insulating Firebrick.....         | 2,600° F. (1427° C) |
| C. Castable Refractory (Hearth)..... | 2,550° F. (1399° C) |
| D. Castable Refractory .....         | 2,550° F. (1399° C) |
| E. Insulating Block.....             | 1,900° F. (1038° C) |
| F. Bonding Mortar .....              | 3,200° F. (1760° C) |
15. Chamber Volumes (not including external flues, stacks or chimneys)
- |                            |                                     |
|----------------------------|-------------------------------------|
| A. Primary Chamber.....    | 64 cubic feet (1.8 m <sup>3</sup> ) |
| B. Secondary Chamber ..... | 74 cubic feet (2.1 m <sup>3</sup> ) |
16. Emission Control Features
- |  |          |
|--|----------|
| A. Secondary Chamber with Afterburner .....                            | Included |
| B. Opacity Monitor and Controller with Visual and Audible Alarms ..... | Included |
| C. Auxiliary Air Control System.....                                   | Included |
| D. Microprocessor Temperature Control System ....                      | Included |
17. Operating Temperatures
- |                            |   |
|----------------------------|---|
| A. Primary Chamber.....    | 32° F. - 1,800° F. (0° C - 982° C)                  |
| B. Secondary Chamber ..... | 1,400° F. - 1,800° F. (760° C - 982° C) as required |
18. Secondary Chamber Retention Time .....
- > 1 second
19. Ash Removal .....
- Door functions as a heat shield. Sweep out beneath front door into hopper that fills collection pan.

SPECIFICATIONS- Model Power-Pak I

- 20. Safety Interlocks
  - A. High Gas Pressure ..... Optional
  - B. Low Gas Pressure..... Optional
  - C. Blower Air Pressure ..... Included
  - D. Door Position ..... Included
  - E. Opacity..... Included
  - F. Motor Starter Function..... Included
  - G. Chamber Temperature..... Included
  - H. Motor Overload ..... Included
  - I. Flame Quality..... Included
  - J. Burner Safe Start ..... Included
  - K. Cremation Burner/Door Interlock..... Available upon Env. Agency requirements
  
- 21. Burner Description ..... The nozzle mix burners used on this cremation equipment are industrial quality and designed for incinerator use.
  
- 22. Ultraviolet Flame Detection ..... Ultraviolet flame detection has proven to be the most reliable means of flame safety. The system is completely sealed in a quartz capsule to eliminate problems, caused by moisture and dust created in the cremation process, which effect flame rod detectors.
  
- 23. Operating Panel Indicators
  - A. Safe Run ..... Included
  - B. Door Closed ..... Included
  - C. Pollution Alarm..... Included
  - D. Afterburner On (Secondary Burner)..... Included
  - E. Afterburner (Secondary Burner) Reset..... Included
  - F. Cremation Burner Reset..... Included
  - G. High Fire Cremation Burner ..... Included
  - H. Low Fire Cremation Burner ..... Included
  - I. Hearth Air..... Included
  - J. Throat Air Off ..... Included
  
- 24. Automatic Timer Functions
  - A. Master Cycle ..... Included
  - B. Hearth Air..... Included
  - C. Throat Air ..... Included
  - D. Pollution Monitoring..... Included
  - E. Cremation Burner Hi - Low..... Included
  - F. Cool Down ..... Included
  
- 25. Exterior Finish
  - A. Primer ..... 2 coats rust inhibiting
  - B. Finish ..... 2 coats textured finish

SPECIFICATIONS- Model Power-Pak I

- 26. Start-Up and Training..... Startup of cremation equipment and training of operators to properly operate and maintain the equipment is performed on-site under actual operating conditions. Included is a comprehensive owner's manual, with details on the equipment, its components and proper operation.
  
- 27. Environmental Submittals ..... Complete technical portion of state environmental permits. Engineering calculations, technical data, existing stack test results and equipment blueprints provided.

**NOTES:**

- 1) CONTROL CABINET CAN BE MOUNTED ON THE LEFT OR RIGHT SIDE, OR REMOTELY.
- 2) CHAMBER WIDTH IS 39" [0.99m].
- 3) STACK CAN BE LOCATED ON THE BACK LEFT OR BACK RIGHT OF UNIT

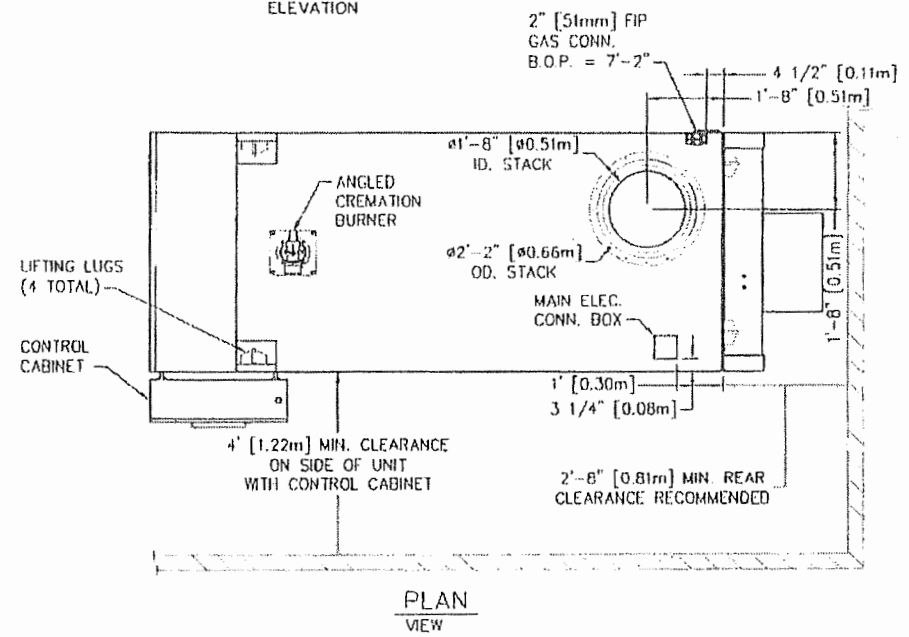
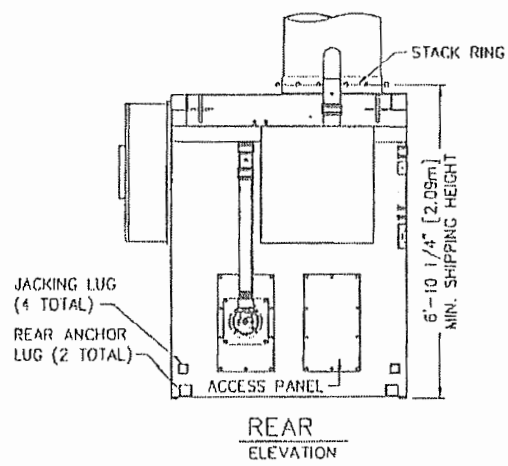
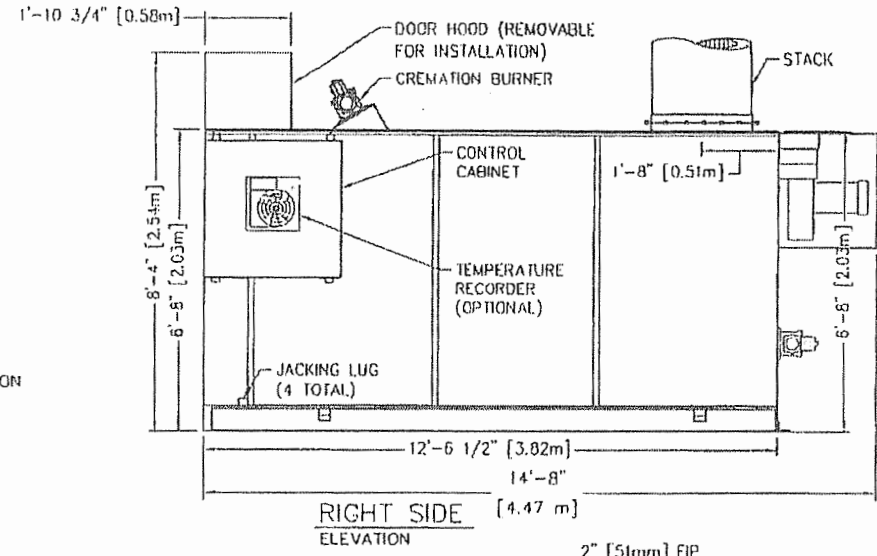
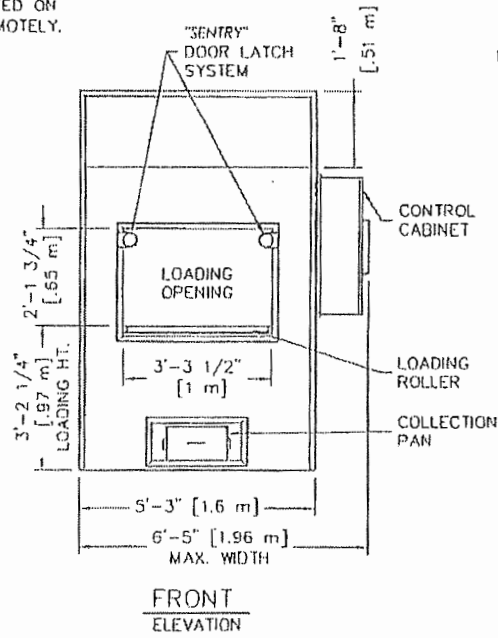

O:\ENG\WCD\_NEW\_SYSTEM\OPERATIONS\PP\SHOP\APPL\_09-003-004.DWG

**Matthews**  
 ENVIRONMENTAL SOLUTIONS  
 2045 Sprint Boulevard  
 Apopka, Florida 32703  
 USA

**POWER-PAK I**

PLAN & ELEVATIONS INCL: CLEARANCES,  
 REQUIREMENTS & RECOMMENDATIONS

DRAWN BY:	JG	DATE:	03.20.2014	REVISION:	
APPROVED BY:		DATE:	12.09.2014	3	GENERAL MODIFICATIONS 2
SCALE:	1/4" = 1'-0"	SHEET:	OF:	4	12.23.2014 GENERAL MODIFICATIONS 3
DWG FILE:				5	10.21.2015 WHISPER SHIELD ADDED
DWG NUMBER:			09-003		

**CREMATOR CLEARANCES**

	RECOMMENDED	MINIMUM
TOP: ②	2 FEET [610 mm]	6 INCHES [152 mm]
CABINET SIDE:	4 FEET [1.22 m]	4 FEET [1.22 m]
OTHER SIDE:	2 FEET [610 mm]	6 INCHES [152 mm]
FRONT:	9 FEET [2.74 m]	0 FEET [2.44 m]
REAR:	3 FEET [0.91 m]	32 INCHES [812 mm]
STACK:	9 INCHES [229 mm]	6 INCHES [152 mm]

- FOR CLEARANCES OTHER THAN THOSE SHOWN, OR FOR SPECIAL REQUIREMENTS, CONSULT YOUR MCD REP.
- FROM HIGHEST POINT ON UNIT.
- CONTROL CABINET MOUNTS ON UNIT'S LEFT OR RIGHT SIDES. OR REMOTELY (SEE PLAN VIEW, SHEET 1).
- REAR OF UNIT REFERS TO THE "BACK PLATE", RATHER THAN THE BACK OF THE "WHISPER SHIELD". (SEE PLAN VIEW, SHEET 1).

**CREMATOR REQUIREMENTS**

FUEL: A PRESSURE REGULATOR ADJUSTABLE TO 11" [279 mm] W.C. FOR NATURAL GAS, OR 11" [279 mm] W.C. FOR LP GAS.

CAPACITY: RANGES FROM 2.0 TO 3.0 MILLION BTU/HR [2.1 TO 3.1 MILLION KILOJouLES/HR] DEPENDING UPON AMOUNT OF BURNERS.

ELECTRICAL: 230 VOLT, 3ø, (40A BREAKER) AND 115v (10A BREAKER), OR 230 VOLT, 1ø, (70A BREAKER) AND 115v (10A BREAKER) 50/60 HERTZ

AIR: LOUVER NEAR THE REAR OF THE UNIT CAPABLE OF PASSING 2,500 CU FT/MIN [70.8 CU M/MIN] OF FREE AIR (36" X 36") [914 mm X 914 mm].

**STACK INSTALLATION INSTRUCTIONS**

- APPLY A 1/2" THICK MORTAR JOINT TO EXPOSED REFRACTORY SURFACE IN STACK RING. LOWER THE BASE STACK SECTION (B) ONTO STACK RING (A) AND FASTEN WITH HARDWARE PROVIDED (NO MORE THAN (2) STACK SECTIONS SHALL BE LIFTED TOGETHER). REPEAT PROCESS FOR REMAINING STACK SECTIONS. IF SECTIONS OF VARYING LENGTHS ARE SUPPLIED, ASSEMBLE AS TO AVOID FLANGES & LIFTING EYES INTERFERING WITH RAIN COLLAR LOCATION.
- INSTALL STORM COLLAR ON STACK, 3" [72 mm] ABOVE NON-COMBUSTIBLE LINER (FLASHING), ALLOWING FOR PROPER VENTILATION (SEE DETAIL).
- APPLY A 1/4" [6 mm] BEAD OF HIGH-TEMPERATURE SILICON SEALANT (PROVIDED BY MCD) TO THE JOINT BETWEEN THE STORM COLLAR (C) AND THE STACK (B).
- STORM COLLAR IS FURNISHED BY MCD. THE NON-COMBUSTIBLE LINER (FLASHING) TO BE PROVIDED BY THE OTHERS.
- IF FIFTY PERCENT OF THE STACK LENGTH IS ABOVE THE ROOF, GUY WIRES MAY BE REQUIRED. CONSULT WITH YOUR MCD REP.
- RAIN CAP NOT REQUIRED.

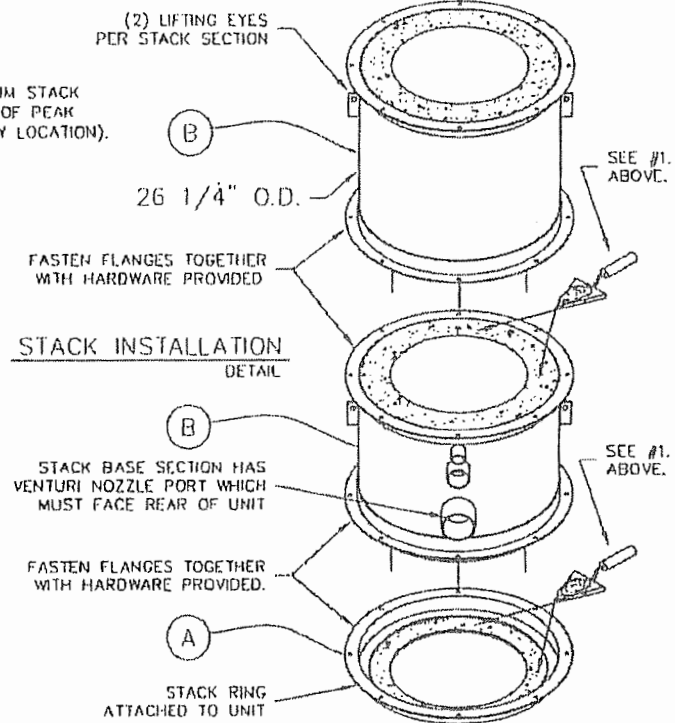
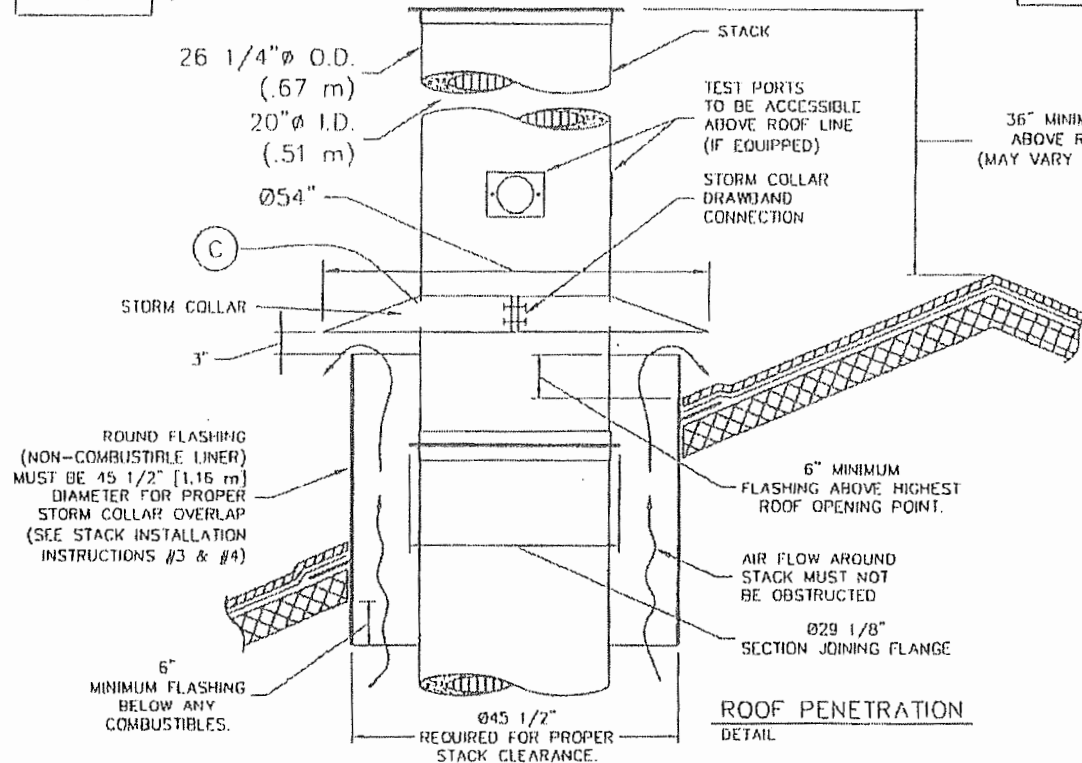

D:\LENS\MCD\_NEW\_SYSTEM\OPERATIONS\PP\SHOP\PP\09-006.DWG

**Matthews**  
 ENVIRONMENTAL SOLUTIONS  
 2045 Sprint Boulevard  
 Aopka, Florida 32703  
 USA

POWER-PAK I  
 STACK DETAILS, CLEARANCES &  
 INSTALLATION INSTRUCTIONS.  
 REFRACTORY STACK DETAIL

DRAWN BY:	JG	DATE:	03.14.2014	REVISION:	
APPROVED BY:	--	DATE:	--	3	12.09.2014 GENERAL MODIFICATIONS 2
SCALE:	1/2" = 1'-0"	SHEET:	OF:	4	12.23.2014 GENERAL MODIFICATIONS 3
DWG FILE:					
DWG NUMBER:			09-006		

## Calculation Of Emissions

### Estimated Emission Calculation

Matthews Environmental Solutions  
(previously Matthews Cremation Division)  
Crematory Incinerator Model IE43-PPI

-4-

Total Incinerator Burn Capacity: 150 lb/hr of remains (type 4) and associated containers (type 0)  
 Flue gas flow rate = 1100 dscfm 12 Hours/Day X 6 Days/Week X 52 Weeks/Year  
 ( 100 % Excess Air) = 3744 Hours/Year

**Total Emission Rate = Incinerator Burn Rate X Emission Factor**

#### Sulfur Dioxide (SO<sub>2</sub>)

$$\frac{150 \text{ lb/hr} \times 2.17 \text{ lb/ton} \times \frac{1 \text{ ton}}{2000 \text{ lbs}}}{1100 \text{ dscfm} \times \frac{60 \text{ min/hr}}{60 \text{ min/hr}} \times \frac{0.0283 \text{ m}^3/\text{ft}^3 \times 2.51 \text{ mg/m}^3}}{0.16275 \text{ lb/hr} \times \frac{4.54\text{E}+05 \text{ mg/lb}}{60 \text{ min/hr}} \times \frac{1 \text{ ppmv}}{0.0283 \text{ m}^3/\text{ft}^3}} = \begin{matrix} 0.163 \text{ lb/hr} \\ 0.3047 \text{ TPY} \\ 15.16 \text{ ppmv} \end{matrix}$$

#### Nitrogen Oxide (NOx - as Nitrogen Dioxide)

$$\frac{150 \text{ lb/hr} \times 3.56 \text{ lb/ton} \times \frac{1 \text{ ton}}{2000 \text{ lbs}}}{1100 \text{ dscfm} \times \frac{60 \text{ min/hr}}{60 \text{ min/hr}} \times \frac{0.028 \text{ m}^3/\text{ft}^3 \times 1.88 \text{ mg/m}^3}}{0.267 \text{ lb/hr} \times \frac{4.54\text{E}+05 \text{ mg/lb}}{60 \text{ min/hr}} \times \frac{1 \text{ ppmv}}{0.028 \text{ m}^3/\text{ft}^3}} = \begin{matrix} 0.267 \text{ lb/hr} \\ 0.4998 \text{ TPY} \\ 34.89 \text{ ppmv} \end{matrix}$$

#### Particulates (PM & PM<sub>10</sub>)

$$\frac{150 \text{ lb/hr} \times 4.56 \text{ lb/ton} \times \frac{1 \text{ ton}}{2000 \text{ lbs}}}{1100 \text{ dscfm} \times \frac{60 \text{ min/hr}}{60 \text{ min/hr}}}{0.342 \text{ lb/hr} \times \frac{7.00\text{E}+03 \text{ gr/lb}}{60 \text{ min/hr}}} = \begin{matrix} 0.342 \text{ lb/hr} \\ 0.6402 \text{ TPY} \\ 0.04 \text{ gr/dscf} \end{matrix}$$

#### Carbon Monoxide (CO)

$$\frac{150 \text{ lb/hr} \times 2.95 \text{ lb/ton} \times \frac{1 \text{ ton}}{2000 \text{ lbs}}}{1100 \text{ dscfm} \times \frac{60 \text{ min/hr}}{60 \text{ min/hr}} \times \frac{0.028 \text{ m}^3/\text{ft}^3 \times 1.14 \text{ mg/m}^3}}{0.22125 \text{ lb/hr} \times \frac{4.54\text{E}+05 \text{ mg/lb}}{60 \text{ min/hr}} \times \frac{1 \text{ ppmv}}{0.028 \text{ m}^3/\text{ft}^3}} = \begin{matrix} 0.2213 \text{ lb/hr} \\ 0.4142 \text{ TPY} \\ 47.68 \text{ ppmv} \end{matrix}$$

**Notes:**

1. Incinerator Emissions based on EPA emissions from Table 2.3-1 and 2.3-2 of AP-42 (5th Edition)
2. All conversion factors from AP-42 Appendix A.

CREMATOR MASS BALANCE  
 Matthews Environmental Solutions  
 PPI

THESE CALCULATIONS HAVE BEEN PREPARED TO EVALUATE THE COMBUSTION  
 PROCESS IN THIS UNIT

THE INCINERATOR INSTITUTE OF AMERICA HAS PUBLISHED THE FOLLOWING SPECIFICATIONS  
 COVERING AVERAGE WASTES.

WASTE TYPE	TYPE 0	TYPE 4
BTU PER POUND	8500	10000
POUND ASH PER POUND WASTE	0.95	0.65
POUND MOISTURE PER POUND WASTE	0.1	0.85
POUND COMBUSTIBLES PER POUND WASTE	0.85	0.1
HOURLY CONSUMPTION OF WASTE (LBS)	10	140

1. MASS OF PRODUCTS OF COMBUSTION FROM CONTAINER

A. COMBUSTION AIR

$$\frac{8500 \text{ BTU/LB}}{100 \text{ BTU/CF OF AIR}^*} \times 0.075 \text{ LB/CF OF AIR} = 6.38 \text{ LB/LB BURNED}$$

B. COMBUSTIBLES AND WATER VAPOR

FROM CHART ABOVE = 0.95 LB/LB BURNED

C. TOTAL FLUE PRODUCT MASS PER LB BURNED

= 7.33 LB/LB BURNED

2. MASS OF PRODUCTS OF COMBUSTION FROM BODY

A. COMBUSTION AIR

$$\frac{10000 \text{ BTU/LB}}{100 \text{ BTU/CF OF AIR}^*} \times 0.075 \text{ LB/CF OF AIR} = 0.75 \text{ LB/LB BURNED}$$

B. COMBUSTIBLES AND WATER VAPOR

FROM CHART ABOVE = 0.95 LB/LB BURNED

C. TOTAL FLUE PRODUCT MASS PER LB BURNED

= 1.70 LB/LB BURNED

SPECIFICATIONS	
PRIMARY BURNER FUEL CONSUMPTION (MMBTU/HR)	0.5
SECONDARY BURNER FUEL CONSUMPTION (MMBTU/HR)	1.4
ADDITIONAL SECONDARY AIR SUPPLIED (CFM)	200
SEC. CHAMBER OPERATING TEMPERATURE (°F)	1600
SECONDARY CHAMBER VOLUME (CU. FT)	74
SEC. CHAMB. CROSS-SECTIONAL AREA (SQ. FT)	2.44
FLAME PORT AREA (SQ. FT)	2.95
MIXING BAFFLES AREA (SQ. FT)	1.36

\*AIR AT STANDARD CONDITIONS

3. TOTAL FLUE PRODUCTS

A. MAXIMUM PRIMARY BURNER GAS USAGE

$$500000 \text{ BTU/HR} \times 4.5E-05 \text{ LBS/BTU} = 27 \text{ LBS/HR}$$

B. COMBUSTION AIR FOR PRIMARY BURNER

$$\frac{500000 \text{ BTU/HR}}{100 \text{ BTU/CF AIR}} \times 1 \text{ Burner} \times 0.075 \text{ LB/CF AIR} = 450 \text{ LBS/HR}$$

C. MAXIMUM SECONDARY BURNER GAS USAGE

$$1400000 \text{ BTU/HR} \times 4.5E-05 \text{ LBS/BTU} = 63 \text{ LBS/HOUR}$$



D. COMBUSTION AIR FOR SECONDARY BURNER

$$\frac{1400000 \text{ BTU/HR}}{100 \text{ BTU/CF AIR}} \times \frac{1}{\text{Burner}} \times 0.075 \text{ LB/CF AIR} = 1050 \text{ LBS/HOUR}$$

E. PRODUCTS FROM TYPE 3 WASTE (CONTAINER)

$$7.33 \text{ LBS/LB BURNED} \times 10 \text{ LB/HR BURN RATE} = 73 \text{ LBS/HOUR}$$

F. PRODUCTS FROM TYPE 4 WASTE (TISSUE)

$$1.70 \text{ LBS/LB WASTE} \times 140 \text{ LB/HR BURN RATE} = 238 \text{ LBS/HOUR}$$

G. ADDITIONAL SECONDARY CHAMBER COMBUSTION AIR (THROAT AIR)

$$12000 \text{ CF/HR} \times 0.075 \text{ LB/CF AIR} = 900 \text{ LBS/HOUR}$$

H. TOTAL FLUE PRODUCTS

$$= \underline{\underline{2801 \text{ LBS/HOUR}}}$$

2. VELOCITY AND TIME CALCULATIONS

A. SCFM CALCULATION

(PRODUCTS ASSUMED TO HAVE DENSITY CLOSE TO AIR)

$$2801 \text{ LBS/HR} \times \frac{13.35 \text{ STD. CU. FT/LB}}{60 \text{ MIN/HR}} = 623 \text{ SCFM}$$

B. TOTAL PRODUCTS ACFM

@ 1800 °F

$$\frac{2050 \text{ °RANKINE}}{530 \text{ °RANKINE}} \times 623.3 \text{ CFM} = 2423 \text{ ACFM}$$

C. RETENTION TIME

$$\frac{74 \text{ CU. FT}}{2423 \text{ ACFM}} \times \frac{60 \text{ SECONDS}}{1 \text{ MINUTE}} = 1.83 \text{ SECONDS}$$

D. VELOCITY IN FLAME PORT

$$\frac{2423 \text{ ACFM}}{2.95 \text{ SQ. FT}} \times \frac{1 \text{ MINUTE}}{60 \text{ SECONDS}} = 13.7 \text{ FEET/SECOND}$$

E. VELOCITY AT MIXING SAFFLES

$$\frac{2423 \text{ ACFM}}{1.36 \text{ SQ. FT}} \times \frac{1 \text{ MINUTE}}{60 \text{ SECONDS}} = 29.7 \text{ FEET/SECOND}$$

F. VELOCITY IN SECONDARY CHAMBER

$$\frac{2423 \text{ ACFM}}{2.44 \text{ SQ. FT}} \times \frac{1 \text{ MINUTE}}{60 \text{ SECONDS}} = 16.5 \text{ FEET/SECOND}$$

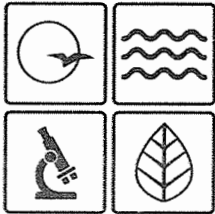

Missouri Department of

dnr.mo.gov

**NATURAL RESOURCES**

Eric R. Greitens, Governor

Carol S. Comer, Director

APR 19 2017

Mr. Michael Liley  
Bollinger County Crematory  
MO Hwy 51 South  
Marble Hill, MO 63764

RE: New Source Review Permit, Permit by Rule  
Project Number: 2017-04-014  
Facility ID Number: 017-0024

Dear Mr. Liley:

Enclosed with this letter is your permit to construct. The entire permit must be retained in your files. Please review your permit carefully. The reverse side of your permit certificate has important information concerning standard permit conditions and your rights and obligations under the laws and regulations of the State of Missouri. *Section A: General Notification Information* and *Section B: Special Conditions for Crematories and Animal Incinerators* are part of your permit. *Section C: Other Potentially Applicable Requirements* of your original application should be replaced with the attached page, a revised Section C. The application forms located on our website, specifically Section C, contain outdated rule references. Many of the rules for certain geographical areas have been rescinded and consolidated into state-wide rules. The attached Section C has been revised to reflect the current applicable rules.

Operation in accordance with these conditions is necessary for continued compliance. An on-site compliance inspection will be performed at a later date, to validate your statements and conditions claimed on the permit by rule notification. If you would like the department to meet with you to discuss how to understand and satisfy the requirements contained in this permit, an appointment referred to as a Compliance Assistance Visit (CAV) can be set up with you. To request a CAV, please contact your local regional office or fill out an online request. The regional office contact information can be found at the following website: <http://dnr.mo.gov/regions/>. The online CAV request can be found at <http://dnr.mo.gov/cav/compliance.htm>.



Recycled paper

Mr. Michael Liley  
Page Two

If you have any questions regarding this permit, please do not hesitate to contact me at (573) 751-4817, or you may write to me at the Department of Natural Resources' Air Pollution Control Program, P.O. Box 176, Jefferson City, Missouri 65102. Thank you for your attention to this matter.

Sincerely,

AIR POLLUTION CONTROL PROGRAM



Kendall Hale, P.E.  
Permits Section Chief

KH:shj

Enclosures

c: Southeast Regional Office  
PAMS File 2017-04-014  
Enclosures

Permit Number: **042017-008**